

Extruded Products

Marine	39
Transport	42
Insulation	45
Architectural	48
Sign Profiles	58

Updates

Due to continuous product development, some information may have been updated since the time of publishing this manual. Altus reserves the right to amend specifications and make changes to products without prior notice and without incurring any obligation. Altus accepts no responsibility for loss or consequential loss due to inaccuracies at the time of publishing or of subsequent changes made. Altus will keep www.altus.co.nz updated. The manual is subject to copyright by the proprietors, Altus NZ Ltd.

The information contained in this catalogue is true and correct to the best of our knowledge. Any recommendations or specifications are made without guarantee on the part of Altus NZ Ltd. Altus NZ Ltd disclaim any liability in connection with the use of this information.

© 2018 All Rights Reserved.

Marine

Extruded Products

Bulb Stringers Type A

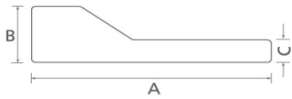

Die Number	A (mm)	B (mm)	C (mm)	Mass kg/m	Perimeter (mm)	Ex Stock
E13306	75.00	15.00	6.00	1.660	172	•

Bulb Stringers Type B

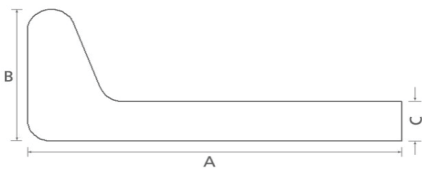

Die Number	A (mm)	B (mm)	C (mm)	Mass kg/m	Perimeter (mm)	Ex Stock
609528	50.00	25.00	6.00	1.104	132	•

✓ Stocked

• Mill runs only, Subject to minimum quantities - please ask regarding the availability of these.

Please note that diagrams, data and images are used for guidance purposes only. For correct details please request a specific die drawing from Altus Customer Services as radius locations and other specifications may vary. All peripheries less than 100mm are deemed 100mm for surface finish purpose.

Marine

Extruded Products

Curved Channels

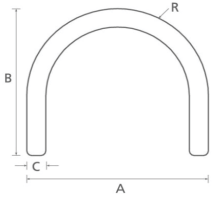

Die Number	A (mm)	B (mm)	C (mm)	R (Radii) (mm)	Mass kg/m	Perimeter (mm)	Ex Stock	Stocked Length (mm)	Stocked Alloy Temper	Mill Finish SAP Code
E04215	38.00	32.00	4.00	1.00	0.855	165	✓	5000	6261 T5	805950
609609	40.00	30.00	3.00	20.00	0.291	159	•			
E13634	50.00	36.00	5.00	20.00	1.228	191	✓	5000	6060 T591	830364
609610	50.00	35.00	4.00	25.00	2.075	190	•			
E05903	60.00	45.00	5.00	30.00	1.704	239	•			
609611	60.00	45.00	5.00	30.00	0.562	240	•			
E13635	75.00	55.00	7.20	37.50	2.759	296	•			
E12244	100.00	75.00	6.00	50.00	4.397	406	•			

✓ Stocked

• Mill runs only, Subject to minimum quantities - please ask regarding the availability of these.

Please note that diagrams, data and images are used for guidance purposes only. For correct details please request a specific die drawing from Altus Customer Services as radius locations and other specifications may vary. All peripheries less than 100mm are deemed 100mm for surface finish purpose.

E11710 - Perspec Cap

Mass - 0.134 kg/m
 Perimeter - 69 mm
 Stocked 5m - 6060T4 - 821306

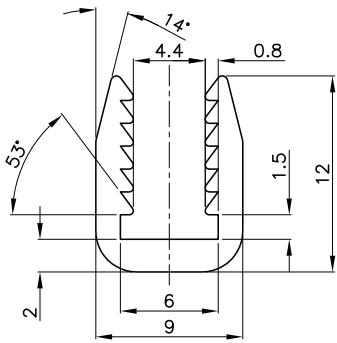

E03609 - Windscreen Mould

Mass - 0.361 kg/m
 Perimeter - 97 mm
 Stocked 5.5m - 6060T4 - 811188

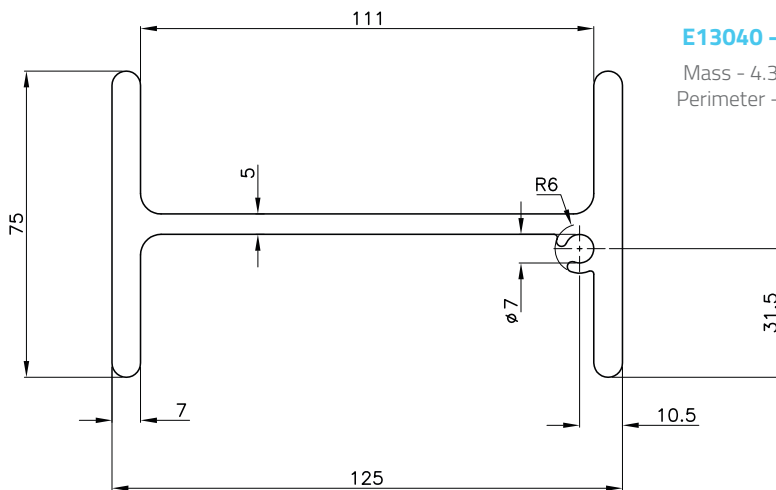
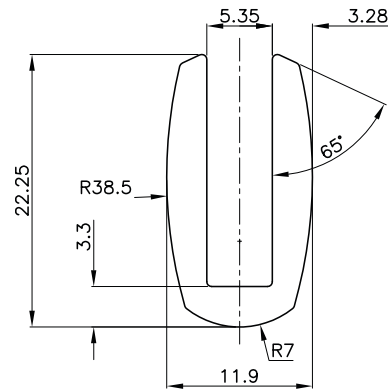

E13040 - I Beam

Mass - 4.397 kg/m
 Perimeter - 534 mm

Mill runs only, Subject to minimum quantities - please ask regarding the availability of these.

Please note that diagrams, data and images are used for guidance purposes only. For correct details please request a specific die drawing from Altus Customer Services as radius locations and other specifications may vary. All peripheries less than 100mm are deemed 100mm for surface finish purpose.

Transport

Extruded Products

E00266 - Legged RHS

Mass - 1.347 kg/m
 Perimeter - 265 mm
 Fits - E00267

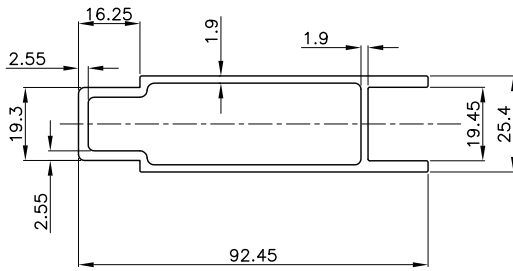

E04128 - Jointer

Mass - 5.606 kg/m
 Perimeter - 581 mm

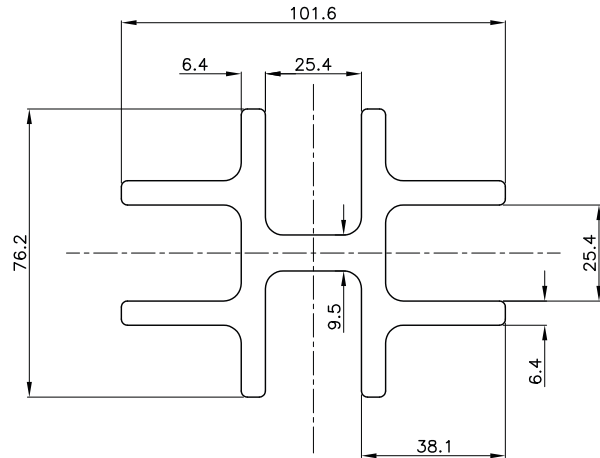

609312 - One Leg Awning

Mass - 0.228 kg/m
 Perimeter - 95 mm

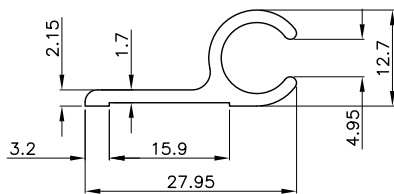

E03490 - One Leg Awning

Mass - 0.188 kg/m
 Perimeter - 102 mm
 Stocked 5m - 6060T5 - 803647

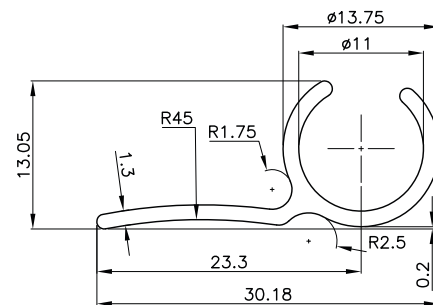

Mill runs only, Subject to minimum quantities - please ask regarding the availability of these.

Please note that diagrams, data and images are used for guidance purposes only. For correct details please request a specific die drawing from Altus Customer Services as radius locations and other specifications may vary. All peripheries less than 100mm are deemed 100mm for surface finish purpose.

Transport

Extruded Products

E03637 - Jointer

Mass - 0.851 kg/m
Perimeter - 123 mm

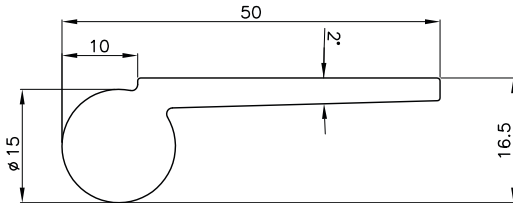

E06839 - Handrail

Mass - 1.533 kg/m
Perimeter - 353 mm

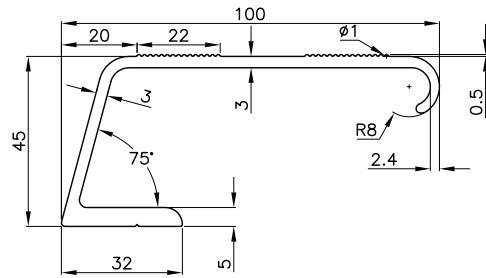

E04886 - P Section

Mass - 1.154 kg/m
Perimeter - 253 mm

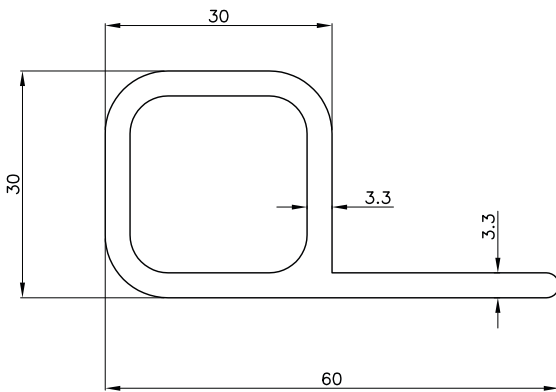

Mill runs only, Subject to minimum quantities - please ask regarding the availability of these.

Please note that diagrams, data and images are used for guidance purposes only. For correct details please request a specific die drawing from Altus Customer Services as radius locations and other specifications may vary. All peripheries less than 100mm are deemed 100mm for surface finish purpose.

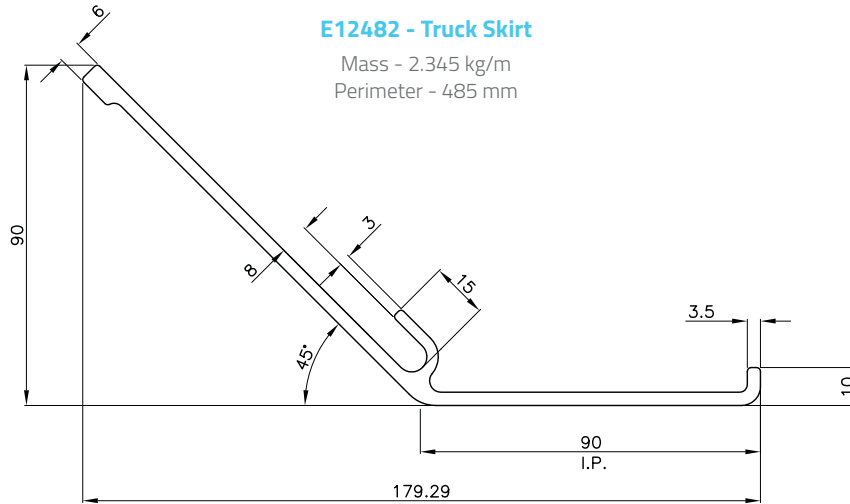

E15840 - Truck Deck
 Mass - 1.634 kg/m
 Perimeter - 577 mm

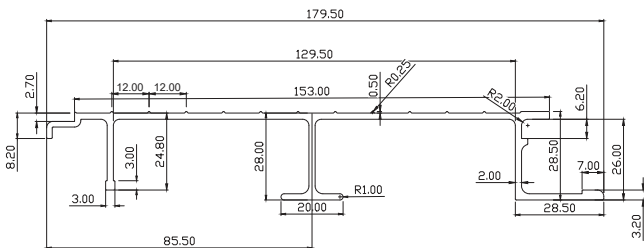

E15839 - Truck Deck - Combing Rail
 Mass - 1.238 kg/m
 Perimeter - 250 mm

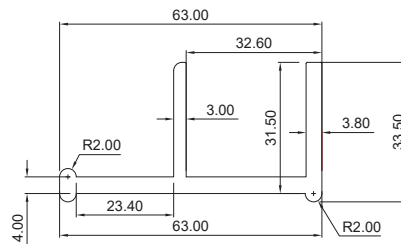

609670 - Runner Board
 Mass - 2.751 kg/m
 Perimeter - 607 mm

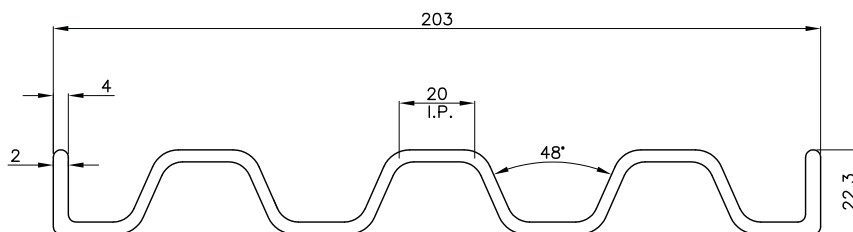

Mill runs only, Subject to minimum quantities - please ask regarding the availability of these.

Please note that diagrams, data and images are used for guidance purposes only. For correct details please request a specific die drawing from Altus Customer Services as radius locations and other specifications may vary. All peripheries less than 100mm are deemed 100mm for surface finish purpose.

Insulation

Extruded Products

E11872 - External Angle

Mass - 0.321 kg/m
Perimeter - 159 mm

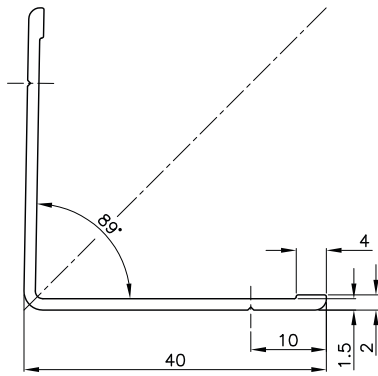

E11873 - Internal Angle

Mass - 0.322 kg/m
Perimeter - 159 mm

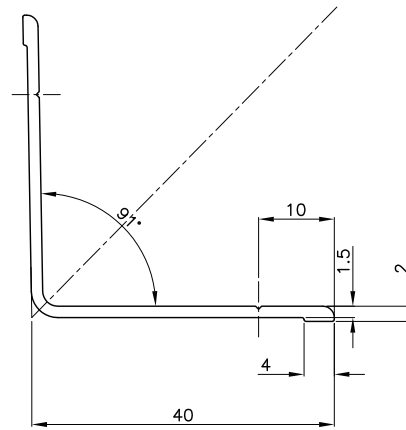

E03867 - Angle

Mass - 1.304 kg/m
Perimeter - 400 mm

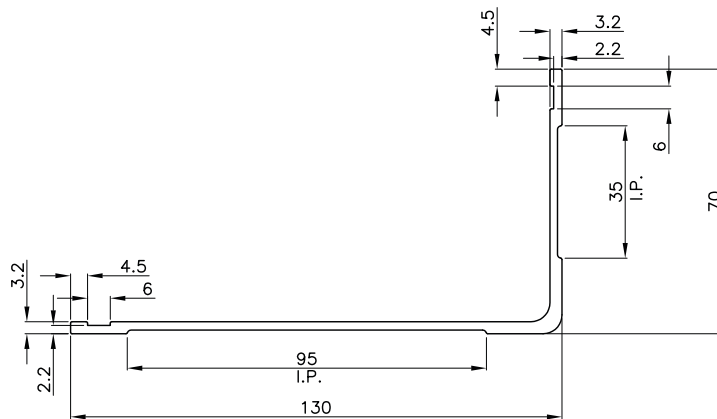

Mill runs only. Subject to minimum quantities - please ask regarding the availability of these.

Please note that diagrams, data and images are used for guidance purposes only. For correct details please request a specific die drawing from Altus Customer Services as radius locations and other specifications may vary. All peripheries less than 100mm are deemed 100mm for surface finish purpose.

Insulation

Extruded Products

E11967 - Channel

Mass - 0.434 kg/m
 Perimeter - 204 mm
 Stocked 6 m - Titania Matt 829662 - 6060T5

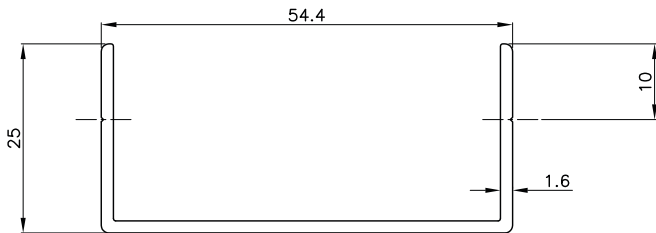

404560 - Channel

Mass - 0.608 kg/m
 Perimeter - 304 mm

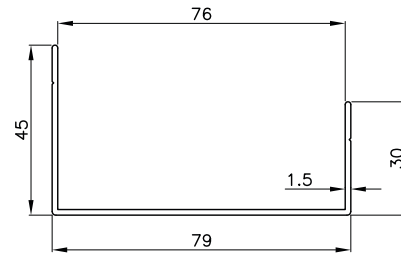

E11968 - Channel

Mass - 0.542 kg/m
 Perimeter - 253 mm

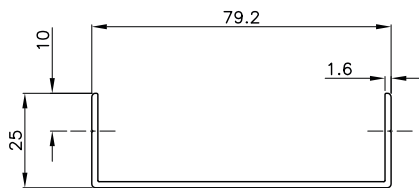

E12809 - Cool Room Cove

Mass - 0.893 kg/m
 Perimeter - 297 mm

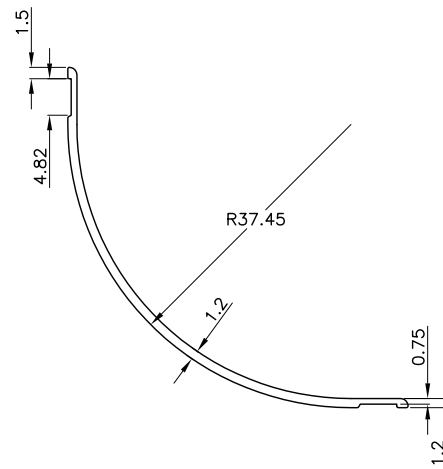

E12813 - Channel

Mass - 0.849 kg/m
 Perimeter - 332 mm

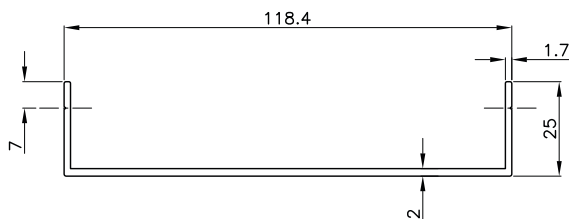

Mill runs only, Subject to minimum quantities - please ask regarding the availability of these.

Please note that diagrams, data and images are used for guidance purposes only. For correct details please request a specific die drawing from Altus Customer Services as radius locations and other specifications may vary. All peripheries less than 100mm are deemed 100mm for surface finish purpose.

Insulation

Extruded Products

E12814 - Channel

Mass - 1.267 kg/m
Perimeter - 401 mm

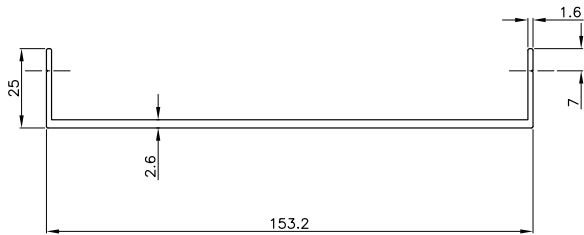

E12807 - 50mm Wall Door Rebate

Mass - 0.785 kg/m
Perimeter - 274 mm

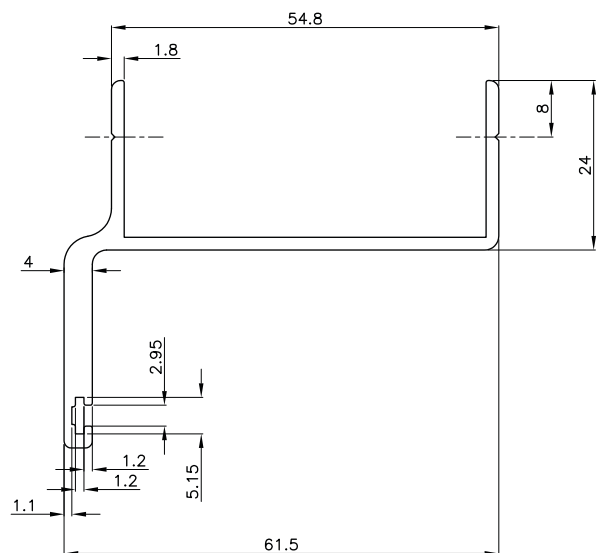

E12806 - 75mm Wall Door Rebate

Mass - 0.994 kg/m
Perimeter - 367 mm

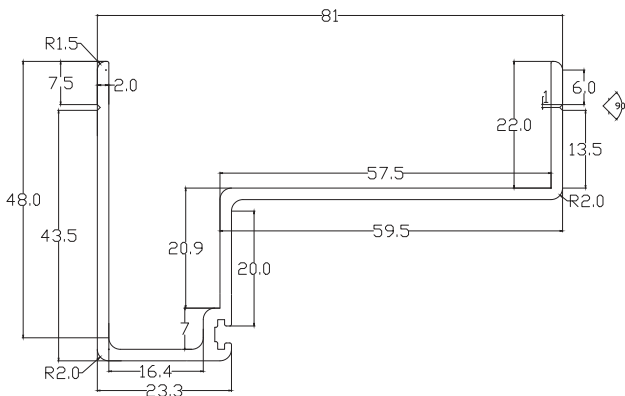

E12805 - 100mm Wall Door Rebate

Mass - 1.129 kg/m
Perimeter - 417 mm

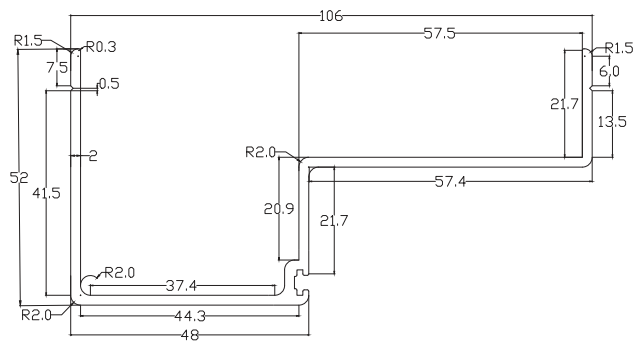

Mill runs only, Subject to minimum quantities - please ask regarding the availability of these.

Please note that diagrams, data and images are used for guidance purposes only. For correct details please request a specific die drawing from Altus Customer Services as radius locations and other specifications may vary. All peripheries less than 100mm are deemed 100mm for surface finish purpose.

Architectural / Louvre

Extruded Products

604506 - Arch. Louvre

Mass - 0.420 kg/m
Perimeter - 195 mm

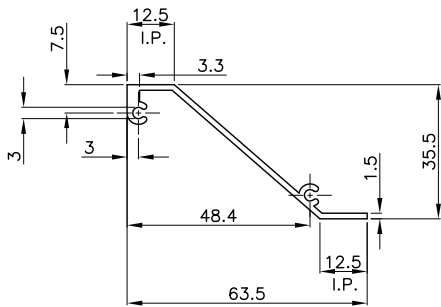

603057 - Arch. Louvre

Mass - 0.461 kg/m
Perimeter - 195 mm

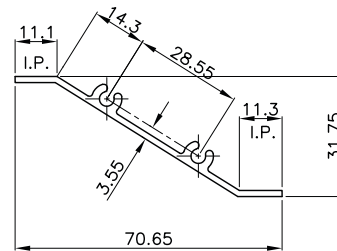

E12395 - Arch Louvre

Mass - 1.084 kg/m
Perimeter - 397 mm

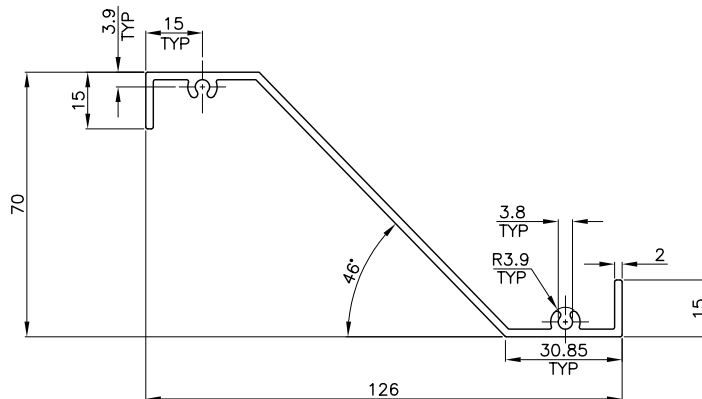

E12396 - Arch Louvre

Mass - 1.274 kg/m
Perimeter - 467 mm

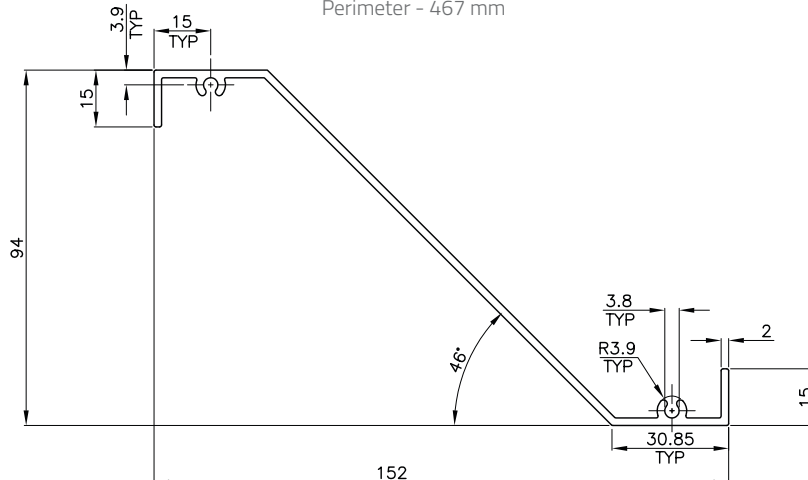

Architectural / Louvre

Extruded Products

E13616 - Louvre

Mass - 1.068 kg/m
Perimeter - 249 mm
Stocked 6 m - 826426 - 6060T5

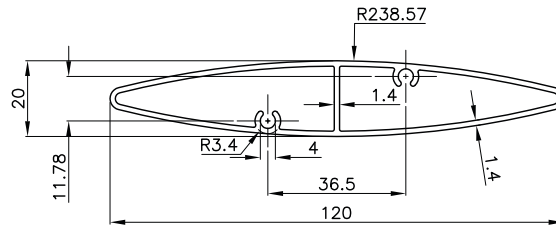

611284 - Louvre

Mass - 2.542 kg/m
Perimeter - 350 mm

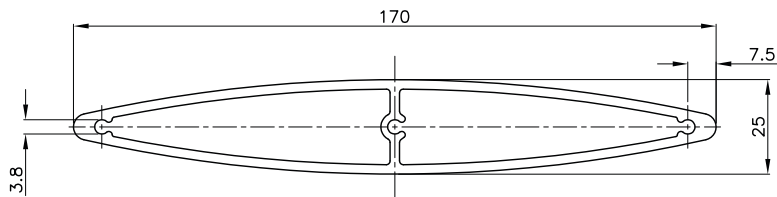

Mill runs only, Subject to minimum quantities - please ask regarding the availability of these.

Please note that diagrams, data and images are used for guidance purposes only. For correct details please request a specific die drawing from Altus Customer Services as radius locations and other specifications may vary. All peripheries less than 100mm are deemed 100mm for surface finish purpose.

Fencing

Extruded Products

E14074 - Paling

Mass - 0.772 kg/m
 Perimeter - 374 mm
 Stocked 6m - 829054 - 6060T5

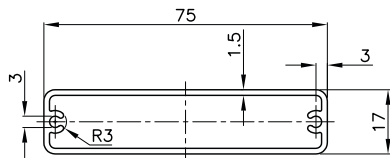

E14073 - Paling

Mass - 1.036 kg/m
 Perimeter - 499 mm
 Stocked 6m - 829052 - 6060T5

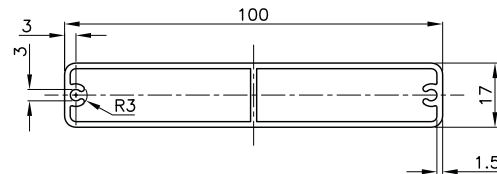

E15772 - T&G Fencing Slat

Mass - 0.952 kg/m
 Perimeter - 412 mm
 Stocked 6m - 872598 - 6060T5

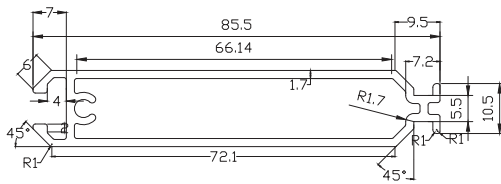

Mill runs only, Subject to minimum quantities - please ask regarding the availability of these.

Please note that diagrams, data and images are used for guidance purposes only. For correct details please request a specific die drawing from Altus Customer Services as radius locations and other specifications may vary. All peripheries less than 100mm are deemed 100mm for surface finish purpose.

E04114 - Window Insect Screen

Mass - 0.237 kg/m
Perimeter - 113 mm

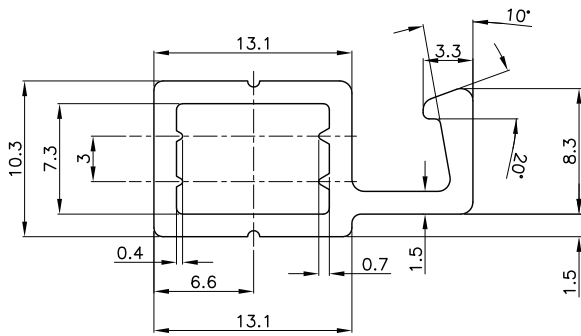

E04273 - Window Insect Screen

Mass - 0.265 kg/m
Perimeter - 131 mm

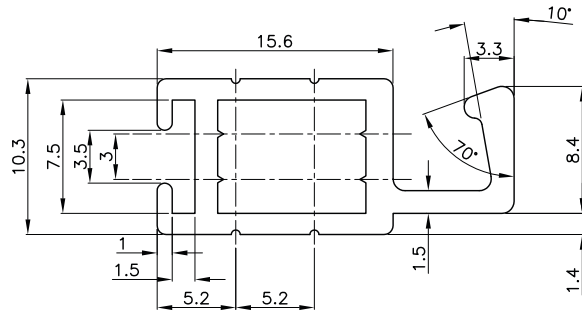

E04174 - Window / Door Insect Screen

Mass - 0.373kg/m
Perimeter - 179 mm

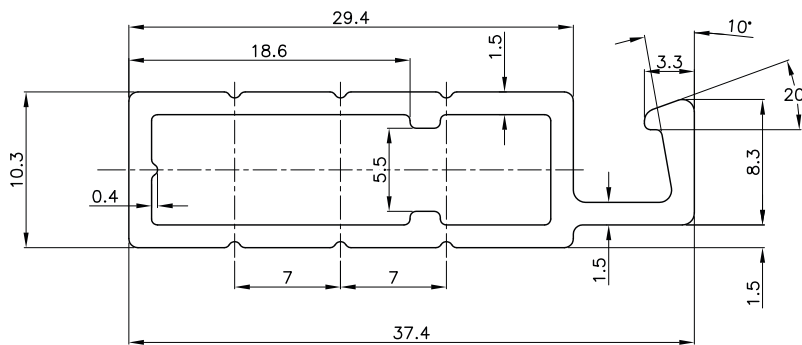

E01723 - Mould

Mass - 0.246 kg/m
Perimeter - 44 mm

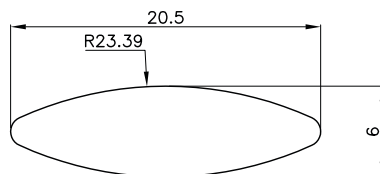

Mill runs only, Subject to minimum quantities - please ask regarding the availability of these.

Please note that diagrams, data and images are used for guidance purposes only. For correct details please request a specific die drawing from Altus Customer Services as radius locations and other specifications may vary. All peripheries less than 100mm are deemed 100mm for surface finish purpose.

Architectural

Extruded Products

E01640 - Bottom Track

Mass - 0.134 kg/m
Perimeter - 64 mm

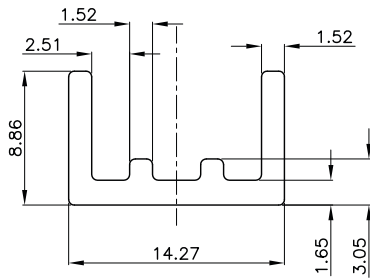

E03815 - Channel / Top Track

Mass - 0.205 kg/m
Perimeter - 97 mm
Stocked 3 m 803651 - 6060T5

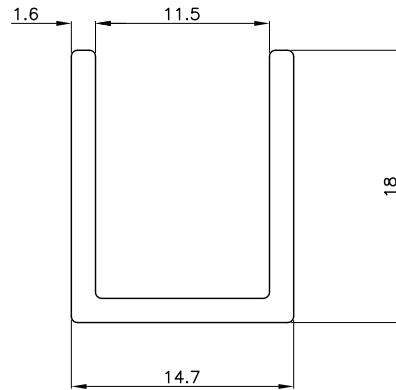

E04338 - Bottom Track

Mass - 0.193 kg/m
Perimeter - 92 mm

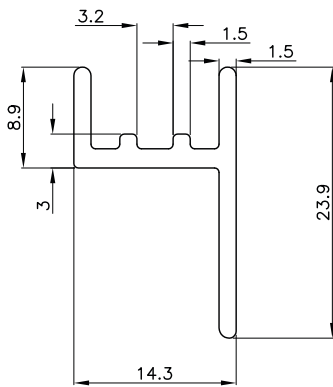

E04337 - Top Track

Mass - 0.233 kg/m
Perimeter - 117 mm

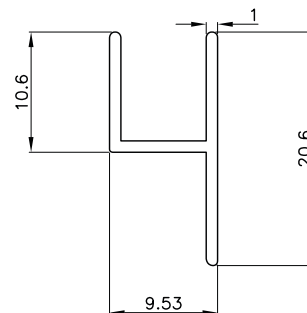

Mill runs only, Subject to minimum quantities - please ask regarding the availability of these.

Please note that diagrams, data and images are used for guidance purposes only. For correct details please request a specific die drawing from Altus Customer Services as radius locations and other specifications may vary. All peripheries less than 100mm are deemed 100mm for surface finish purpose.

609299 - Insect / Security Fixed Frame

Mass - 0.280 kg/m
Perimeter - 142 mm

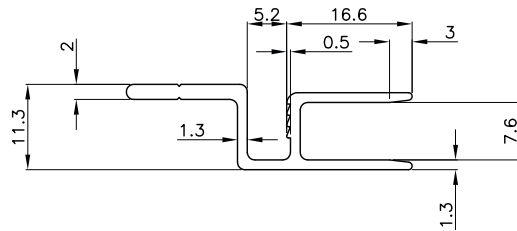

E04852 - Insect / Security Screen Door

Mass - 0.722 kg/m
Perimeter - 348 mm

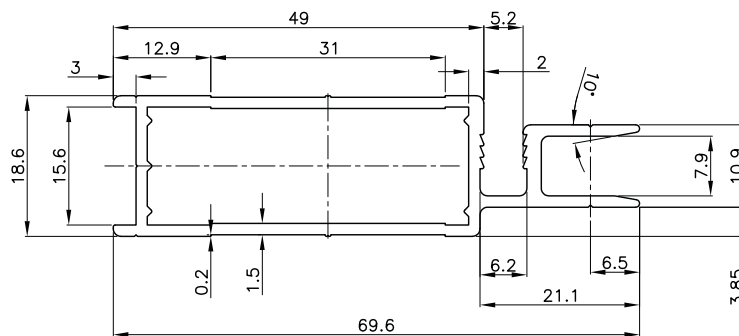

Mill runs only, Subject to minimum quantities - please ask regarding the availability of these.

Please note that diagrams, data and images are used for guidance purposes only. For correct details please request a specific die drawing from Altus Customer Services as radius locations and other specifications may vary. All peripheries less than 100mm are deemed 100mm for surface finish purpose.

E04728 - Staking Angle Window

Mass - 1.471 kg/m
Perimeter - 191 mm
Fits - E04114 & E04273

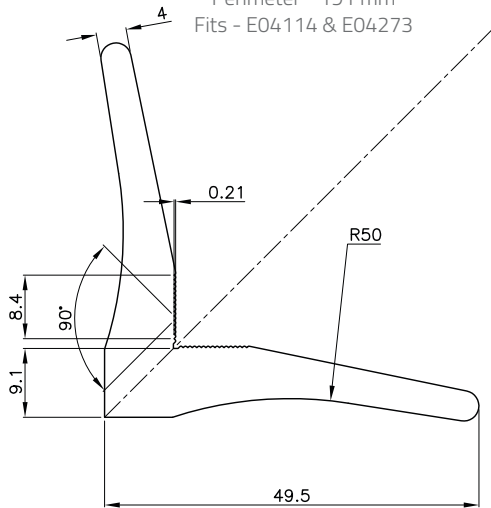

E06899 - Staking Angle Window

Mass - 1.320 kg/m
Perimeter - 189 mm
Fits - E06179

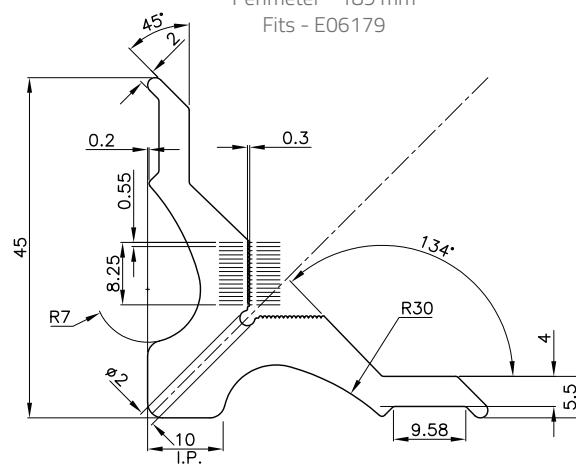

E01310 - Staking Angle Window

Mass - 2.629 kg/m
Perimeter - 293 mm

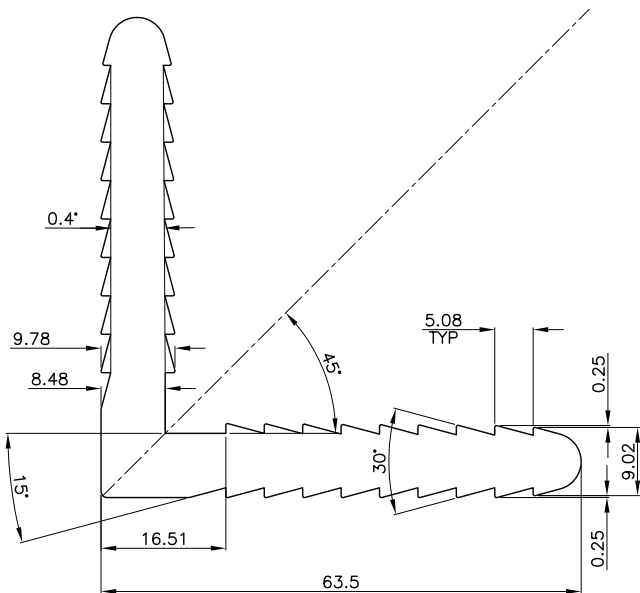

403162 - Staking Angle Window

Mass - 1.499 kg/m
Perimeter - 354 mm

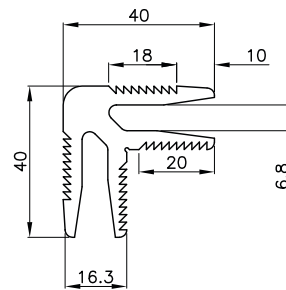

Mill runs only, Subject to minimum quantities - please ask regarding the availability of these.

Please note that diagrams, data and images are used for guidance purposes only. For correct details please request a specific die drawing from Altus Customer Services as radius locations and other specifications may vary. All peripheries less than 100mm are deemed 100mm for surface finish purpose.

Architectural

Extruded Products

E04480 - Angle

Mass - 0.855 kg/m
Perimeter - 161 mm

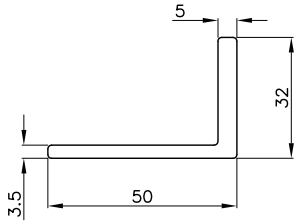

E02731 - Odd Leg Channel

Mass - 0.186 kg/m
Perimeter - 100 mm

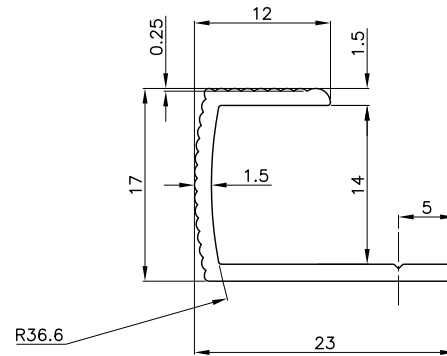

E13591 - Odd Leg Channel

Mass - 1.768 kg/m
Perimeter - 223 mm

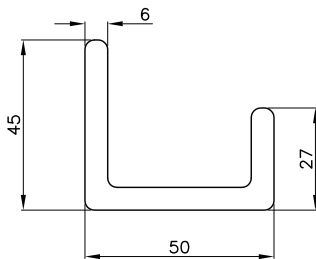

604096 - Lipped Channel

Mass - 3.777 kg/m
Perimeter - 544 mm

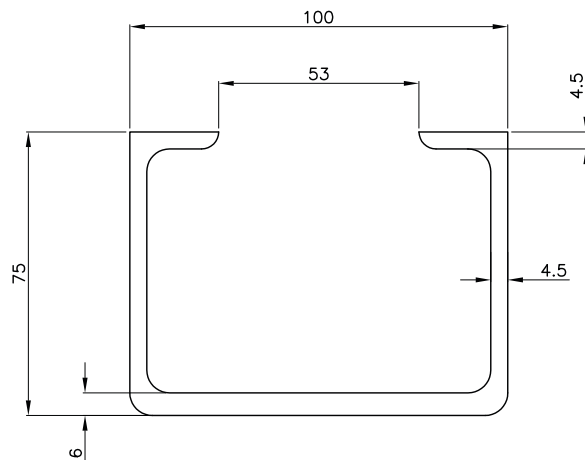

E03694 - Lipped Channel

Mass - 0.888 kg/m
Perimeter - 219 mm

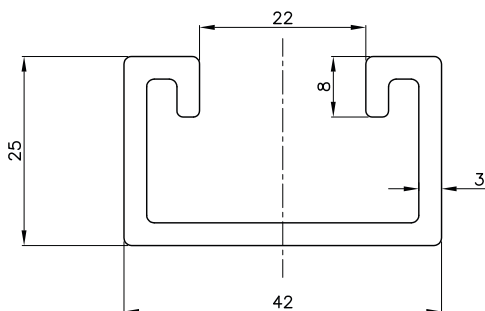

Mill runs only, Subject to minimum quantities - please ask regarding the availability of these.

Please note that diagrams, data and images are used for guidance purposes only. For correct details please request a specific die drawing from Altus Customer Services as radius locations and other specifications may vary. All peripheries less than 100mm are deemed 100mm for surface finish purpose.

E06032 - Sliding Door Track

Mass - 0.479 kg/m
Perimeter - 121 mm
Stocked 5 m - 803720 - 6060T5

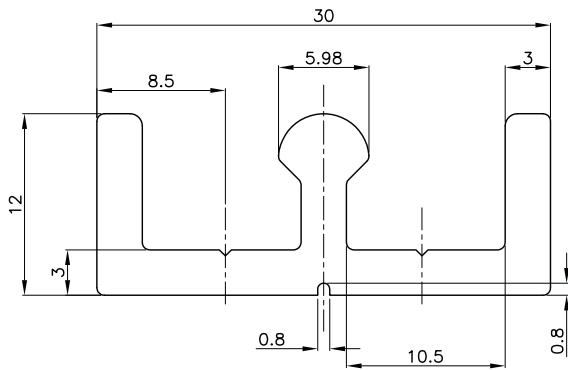

E14108 - Sliding Door Track

Mass - 0.801 kg/m
Perimeter - 149 mm
Stocked 6m - 829328 - 6060T5

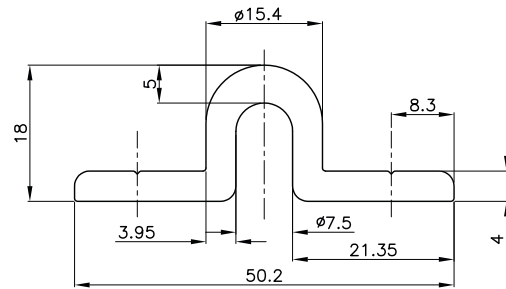

609342 - Threshold

Mass - 1.303 kg/m
Perimeter - 231 mm

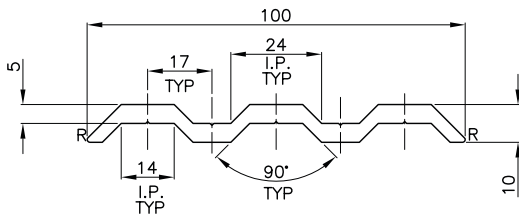

E01248 - PIN

Mass - 0.323 kg/m
Perimeter - 82 mm

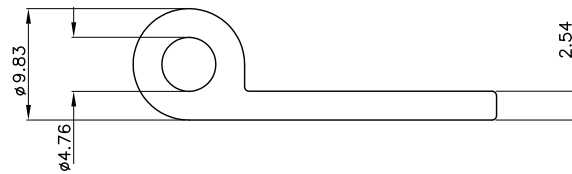

603506 - Channel Lid Clip Fit

Mass - 0.490 kg/m
Perimeter - 174 mm
Fits - 603026

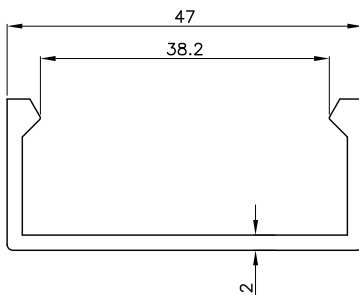

606468 - DIN Rail

Mass - 0.341 kg/m
Perimeter - 145 mm

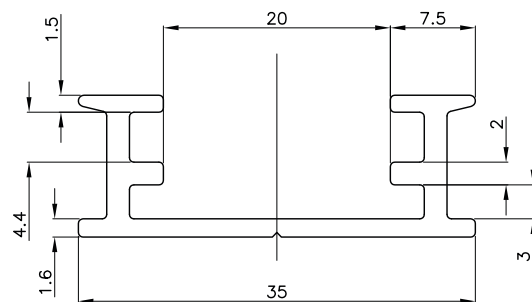

Mill runs only, Subject to minimum quantities - please ask regarding the availability of these.

Please note that diagrams, data and images are used for guidance purposes only. For correct details please request a specific die drawing from Altus Customer Services as radius locations and other specifications may vary. All peripheries less than 100mm are deemed 100mm for surface finish purpose.

Heatsinks

Extruded Products

E03072 - Heat Sink

Mass - 3.53 kg/m
Perimeter - 846 mm

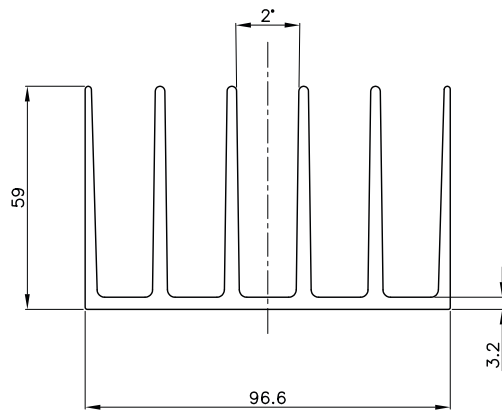

E03398 - Heat Sink

Mass - 3.179 kg/m
Perimeter - 1131 mm

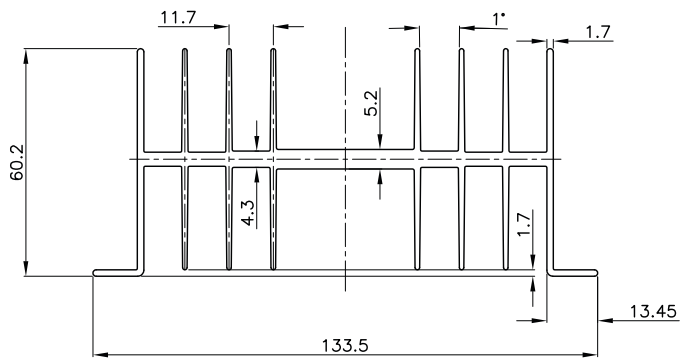

Mill runs only, Subject to minimum quantities - please ask regarding the availability of these.

Please note that diagrams, data and images are used for guidance purposes only. For correct details please request a specific die drawing from Altus Customer Services as radius locations and other specifications may vary. All peripheries less than 100mm are deemed 100mm for surface finish purpose.

Sign profiles

Extruded Products

E12122 - 170mm Sign Frame

Mass - 1.575 kg/m
Perimeter - 510 mm

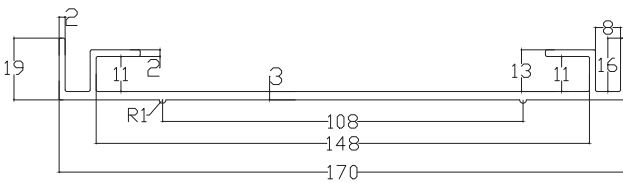

E613719 - 100x32x1.6mm Channel

Mass - 0.747 kg/m
Perimeter - 333.8 mm

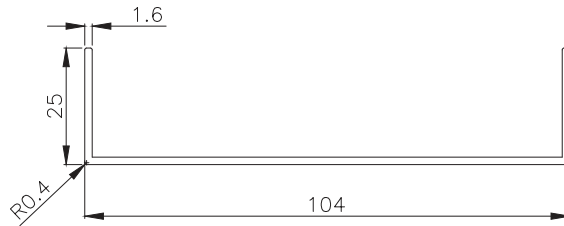

E609792 - 200mm Sign Frame

Mass - 2.279 kg/m
Perimeter - 680.2 mm

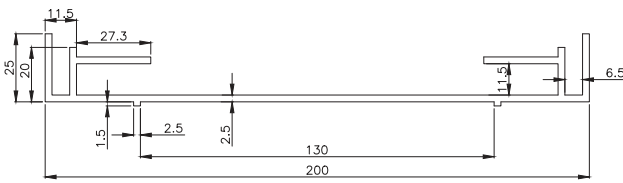

E12123 - 110mm Sign Blade

Mass - 1.131 kg/m
Perimeter - 388 mm

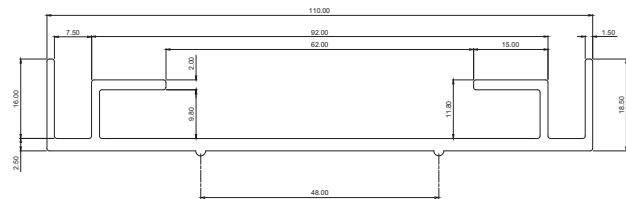

609792 - Sign Blade

Mass - 2.279 kg/m
Perimeter - 680 mm

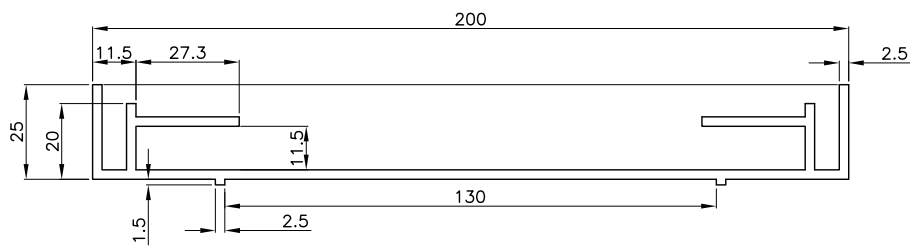

Mill runs only, Subject to minimum quantities - please ask regarding the availability of these.

Please note that diagrams, data and images are used for guidance purposes only. For correct details please request a specific die drawing from Altus Customer Services as radius locations and other specifications may vary. All peripheries less than 100mm are deemed 100mm for surface finish purpose.

Contact details

Altus® NZ Limited - Head Office

49 Business Parade North
East Tamaki
Auckland 2013
New Zealand

PO Box 204123
Highbrook
Auckland 2161
New Zealand

T: 64 9 272 1700

Altus® NZ Limited - Export

49 Business Parade North
East Tamaki
Auckland 2013
New Zealand

PO Box 204123
Highbrook
Auckland 2161
New Zealand

T: 64 9 272 1714

F: 64 9 272 1701

E: export@altus.co.nz

Altus® Mill Orders

Freephone: 0800 77 77 44 - Option 4

E: mill.order@altus.co.nz

Altus® Routers

Freephone: 0800 77 77 44 - Option 5

E: router@altus.co.nz

Altus® Aluminium Trade Centre

49 Business Parade North
East Tamaki
Auckland 2013
New Zealand

PO Box 204123
Highbrook
Auckland 2161
New Zealand

Freephone: 0800 77 77 44 - Option 1

E: sales@altus.co.nz

Altus® Aluminium Trade Centre

61 Hounsell Road
Burbush
Hamilton 3200

Freephone: 0800 77 77 44 - Option 2

E: sales.central@altus.co.nz

Altus® Aluminium Trade Centre

19 McTeigue Road
Halswell
Christchurch 8025

PO Box 37170
Halswell
Christchurch 8245

Freephone: 0800 77 77 44 - Option 3

E: sales.southern@altus.co.nz